

# IP65 HIGH ALTITUDE INSTALLATION DIP SWITCH

## HD406VRH-D



### Features :

1. 5.8GHz microwave motion sensor with dimmable function.
2. Supporting different installation and applications, for surface mounting, traditional LED high bay with aluminium reflector, UFO highbay or linear/triproof high bay.
3. Max. installation height is 15m/49.21ft.
4. 1-10V Dimming
5. Remote control
6. 5 years warranty.

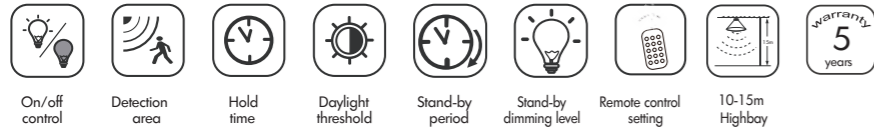

### Technical data

Operating voltage	120-277VAC,50Hz/60Hz
Switching capacity	Max,3.0A@120Vac,50/60Hz; Max,2.0A@277Vac,50/60Hz
Operating temperature	-35°C~+60°C
Stand-by power	≤1W
Control method	On/off / 1-10V Dimming
	Remote control (HD02R/HD03R/HD05R)
Microwave frequency	5.8GHz±75MHz
Microwave power	<0.3mW
Detection area	50%/100%
Hold time	5s/30s/1min/5min/10min/20min/30min
Daylight threshold	2Lux/10Lux/30Lux/50Lux/80Lux/120Lux/Disable
Stand-by period	0s/10s/30s/1min/5min/30min/+∞
Stand-by dimming level	10%/20%/30%/50%
Mounting height	Max.15m ( 49.21ft )
Detection range	Max.ø14m ( 45.93ft )
Motion detection	0.5~1.5m/s
IP rating	IP65
Warranty	5 years

Factory Default Setting: Detection area 100%/ Hold time 5s/ Daylight threshold Disable/Stand-by period 0s/Stand-by dimming level 10%.

### Mechanical structure

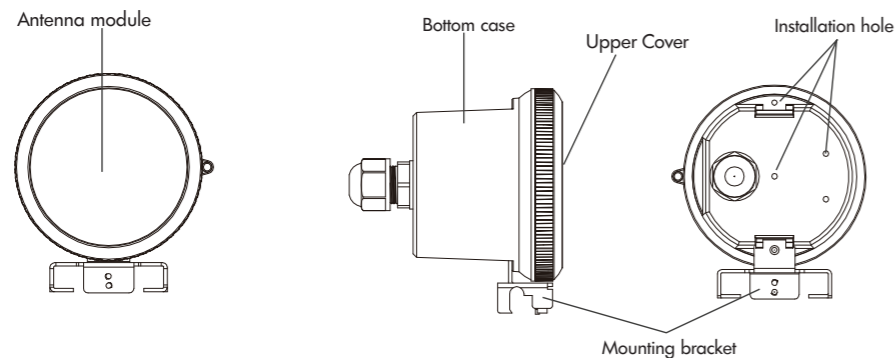

### Wiring diagram

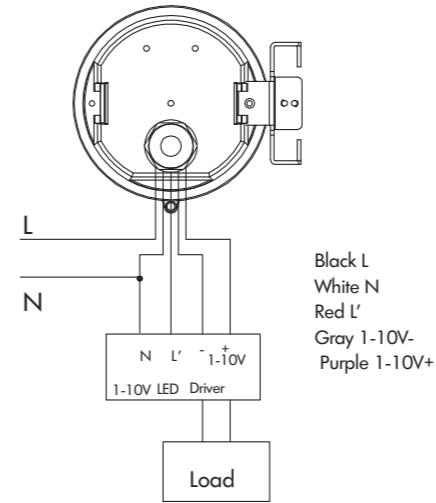

### Installation Method (Unit: mm)

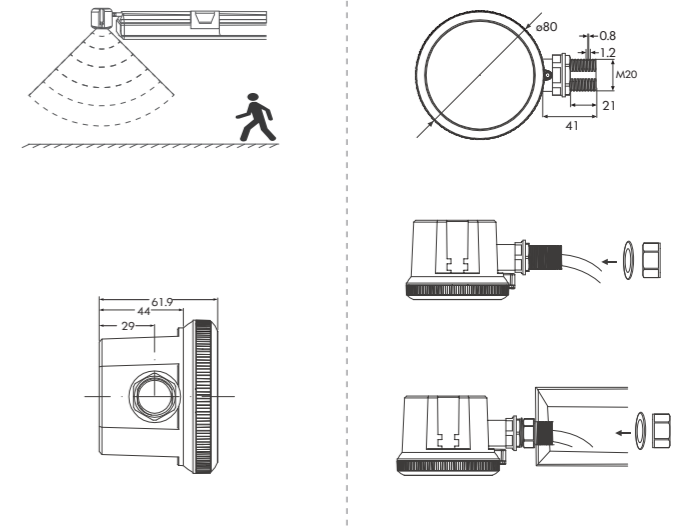

### Settings

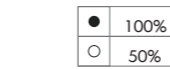
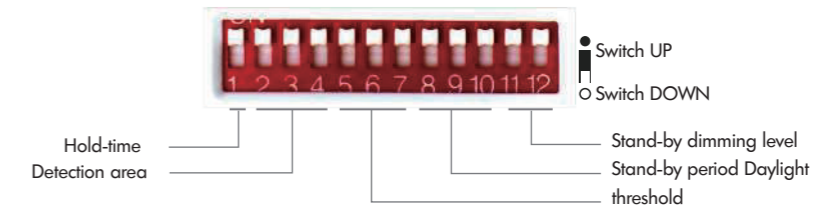

#### Detection area

In this area, movement will be detected and able to trigger the sensor. 100% detection area is also known as the strong sensitivity.

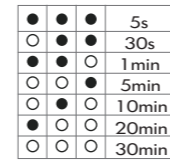

#### Hold-time

The period of light keeping 100% brightness after moving objects leave the detection area.

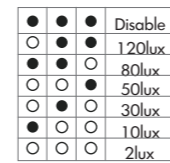

#### Daylight threshold

Definition of the ambient brightness; only when the ambient brightness is lower than the preset specific lux amount, the sensor will work; when it's preset as "disable", the sensor works everytime it detects motion regardless the ambient brightness.

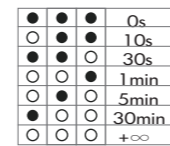

#### Stand-by period

The period of light keeping low output before it's completely switched off. When it's preset as "∞", the light always keep at low output if no movement in the detection area and doesn't turn off.

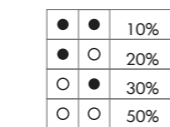

#### Stand-by dimming level

The definition of low output in the standby period.

## Application

### 1. Automatically ON/OFF function:

Light on when detect movement and off after people leave at night. Applications: Corridor, Staircase.



With sufficient daylight, even when motion detected, light remains OFF.

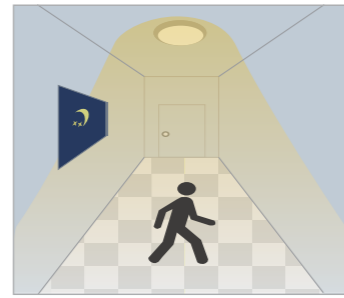

With insufficient daylight, when motion detected, light ON.

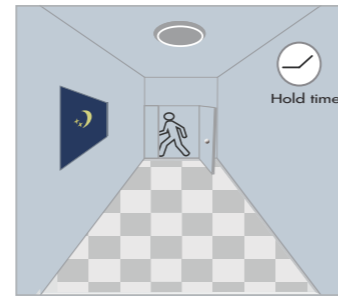

After the last detection and the present hold time elapsed, light OFF.

### 2. No daylight function

The daylight threshold is set to "Disable".

Light on when detect movement. After people leave, Light off after stand-by period. Applications: Dim places such as Basement Parking, Underpass.



When motion is detected, the sensor will switch on the light to 100% brightness.

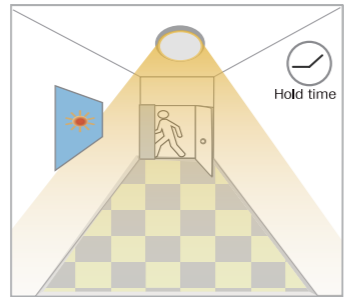

After people leave the detection area, light remains 100% brightness within hold time.

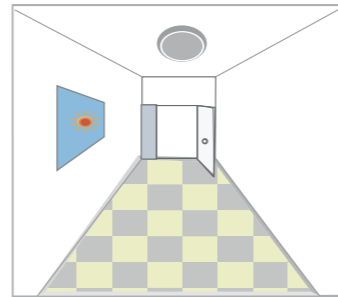

After the last detection and the present hold time elapsed, light OFF.

### 3. Function Demo - Dimmable control/Corridor function

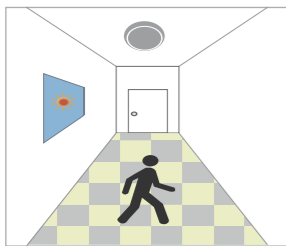

With sufficient daylight, even when motion detected, light remains OFF.



With insufficient daylight, when motion detected, light ON.

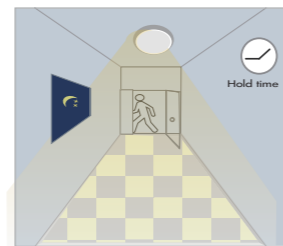

After last detection, the light will be dimmed down to the stand-by dimming level (10%,20%,30% or 50%) after holdtime.

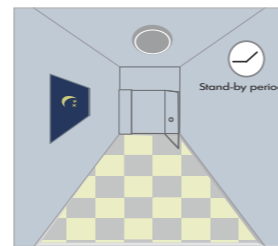

After the stand-by period, light OFF.

## Detection coverage

This figure indicates the maximum distance at the highest mounting height with 100% sensitivity. Typical installation height 8-15m.

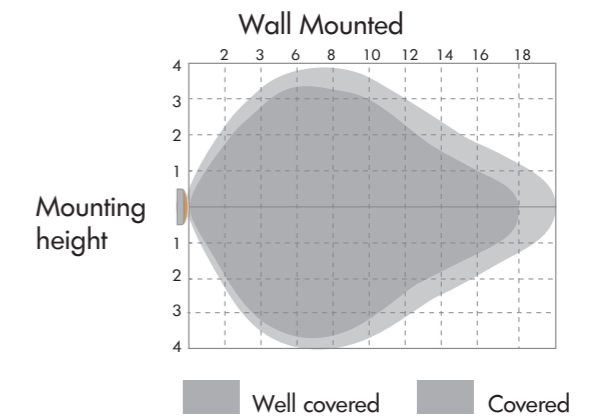
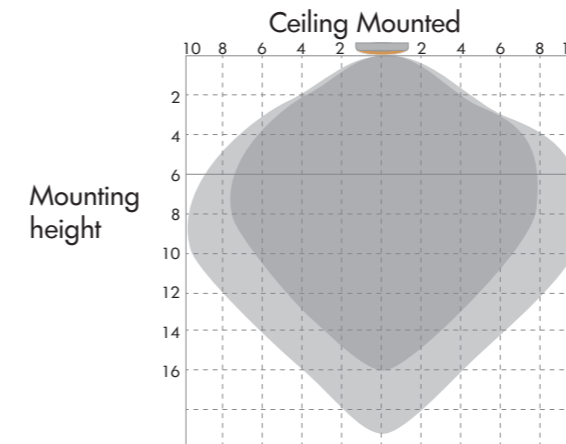

## Attention



### IMPORTANT START-UP INFORMATION:

1. We reserve the right to necessarily modify any incorrect words or pictures or technical parameters.
2. Do NOT rework the sensor without permission or authorization, otherwise the contract clauses guaranteed will be invalid immediately.

### INSTALLATION OVERVIEW :

1. TURN THE POWER OFF AT THE CIRCUIT BREAKER BEFORE INSTALLING THE SENSOR.
2. Do NOT allow bare wires to show; Make sure all connections are secure; Check all the gaskets for watertight fit.
3. Assemble any necessary mounting accessories.
4. Do NOT have any cover above the microwave module.
5. Do keep the sensor away from the driver to avoid possible interference.

### APPLICATIONS :

1. Do NOT mount it outdoor, in case it will be triggered by tree swinging.
2. Do NOT have it at small room or places surrounded with metal material.
3. Do NOT have it around big industrial machine to avoid it getting triggered by vibration.